



Rewarding Learning

ADVANCED (A2)

General Certificate of Education

2023

Centre Number

--	--	--	--	--

Candidate Number

--	--	--	--	--

Technology and Design

Assessment Unit A2 1

assessing

Systems and Control or
Product Design



ATE11

[ATE11]

WEDNESDAY 7 JUNE, AFTERNOON

TIME

2 hours.

INSTRUCTIONS TO CANDIDATES

Write your Centre Number and Candidate Number in the spaces provided at the top of this page and on the A3 pro forma answer pages provided.

Answer **both** questions in **either** Section A, B or C.

Answer to Questions **3(e)(i)** and **(ii)**, **4(b)**, **4(d)**, **5(h)** and **6(i)(i)** and **(ii)** should be made on the A3 pro forma answer pages provided.

At the conclusion of the examination, attach the A3 pro forma answer pages securely to this paper with the treasury tag supplied.

INFORMATION FOR CANDIDATES

The total mark for this paper is 80.

Quality of written communication will be assessed in Question **1(b)**, **3(c)** and **5(d)**.

Figures in brackets printed down the right hand side of the pages indicate the marks awarded to each question or part question.

For Examiner's use only	
Question Number	Marks
1	
2	
3	
4	
5	
6	

Total Marks	
--------------------	--

Section A

Electronic and Microelectronic Control Systems

Answer **both** questions in this section

- 1 (a) A 10k rotary potentiometer (variable resistor) with labelled terminals is shown along with the circuit symbol in **Fig. 1**. The adjuster rotates through 240° and the terminal numbers have been added to the symbol.

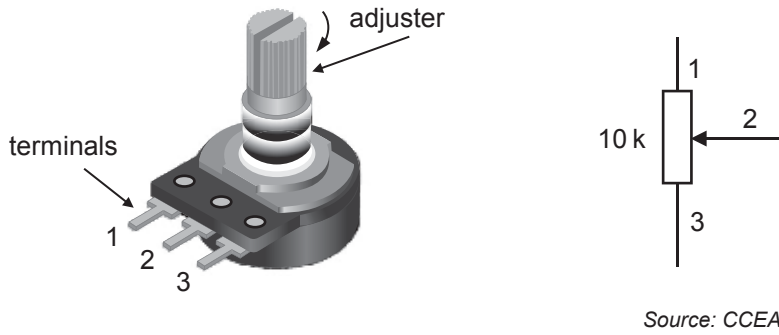

Fig. 1

- (i) Sketch a graph on **Fig. 2** to show how the resistance changes (as measured between terminal 1 and terminal 2) when the adjuster is turned from the fully anticlockwise position to the fully clockwise position.

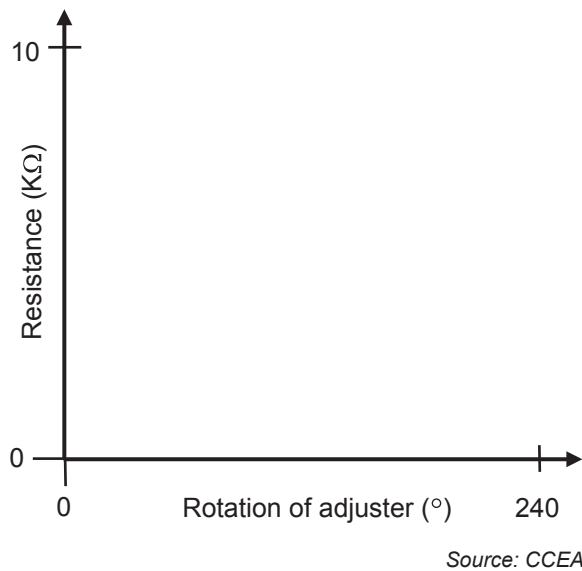
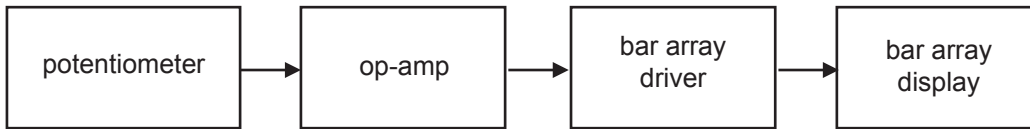

Fig. 2

[2]

Examiner Only	
Marks	Remark

- (ii) A rotary potentiometer is to be used as the input to an electronic system as shown in **Fig. 3**.



Source: CCEA

Fig. 3

Explain why the op-amp in **Fig. 3** can be considered as **continuous** in its operation within the system and the bar array display can be considered as **on/off** in its operation within the system.

Answer continuous _____

 _____ [2]

Answer on/off _____

 _____ [2]

- (iii) The voltage from the potentiometer in **Fig. 3** ranges from 0–1.6 volts while the bar array driver requires a 0–5 volt input range in order to drive a bar array. An amplifier based on an op-amp is required to achieve this. Calculate the required gain for the amplifier.

Answer _____ [2]

- (iv) In the space below draw and label a suitable dual power supply amplifier (based on an op-amp) with the required gain to suit the bar array driver.

[5]

Examiner Only	
Marks	Remark

(b) Op-amps (operational amplifiers) are voltage amplifying integrated circuits that can be configured in different modes for a range of applications. Describe **three** main general characteristics of op-amps that make them suitable for a range of voltage amplifying applications. Then discuss the main features of the **differential** mode arrangement for an op-amp.

Quality of written communication will be assessed in this question.

Characteristic 1 _____

Characteristic 2 _____

Characteristic 3 _____

Examiner Only	
Marks	Remark

Examiner Only	
Marks	Remark

(c) Some details for a concept prototype tractor tilt indicator system are shown in **Fig. 4**. The system is based on a 10 kΩ rotary potentiometer mounted on the front screen of the tractor cab. An output voltage circuit will provide a voltage (V_o) that changes with the tilt of the tractor on sloping ground. The wiper of the potentiometer is kept in the vertical position by a weighted pendulum. The system is designed to detect tilt angles up to 30° on the right and left side. The wiper has a maximum rotation of 240° and when the tractor is level the pendulum will maintain the wiper in the mid (0°) position as shown.

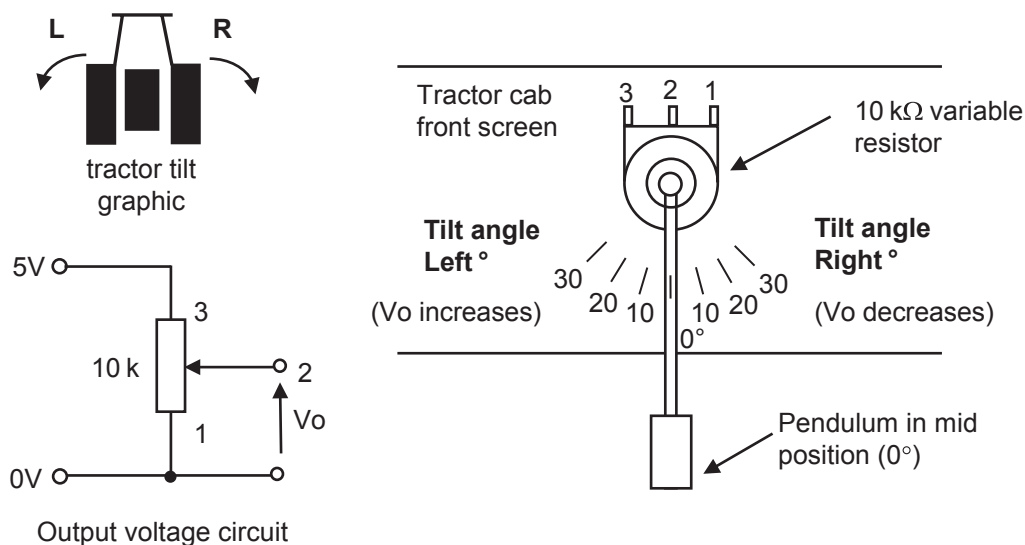

Source: CCEA

Fig. 4

(i) Calculate the voltage V_o at terminal 2 on the potentiometer in **Fig. 4** when the tilt is 20° to the **right** if terminal 1 is connected to 0V and terminal 3 is connected to 5V.

Answer _____ volts [3]

(ii) A PIC with an on board 8 bit analogue to digital converter (ADC) is to be used to convert V_o from the output voltage circuit in **Fig. 4** into digital values. The ADC input voltage can range from 0V to 5V and has an equivalent binary range from 00000000 to 11111111. Calculate the 8 bit binary value that corresponds to an input voltage of 3V.

Answer _____ [3]

- (iii) It has been suggested that the PIC could be upgraded to one with an on board ADC with a higher resolution. Explain **one** main advantage of using an ADC with a higher resolution.

[2]

- (d) The proposed display unit for the tractor tilt indicator system is shown in **Fig. 5**. It houses a common cathode LED bar array which will be used to display the tilt of the tractor.

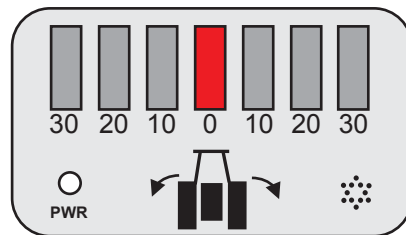

Source: CCEA

Fig. 5

On the blank pages following, design a suitable PIC based circuit with associated flow chart program for the complete tractor tilt indicator system as follows:

- When the tractor is level or less than 10° tilt right or left, the middle bar of the LED bar array should be illuminated as shown in **Fig. 5**.
- The appropriate bars should illuminate depending on which tilt angle is detected to the left or right by the rotary potentiometer arrangement. (only one bar should be illuminated at any time.)
- If the tilt reaches or exceeds 30° to either the left or right the appropriate bar should flash at a rate of 2 Hertz.
- A 12 volt buzzer should simultaneously provide an audible warning until the tilt returns below 30° .
- The system should check the tilt angle once every second.
- A power supply status LED should indicate when the system is operational.

[10]

Examiner Only	
Marks	Remark

Answer page question 1(d)

Answer page question 1(d) (continued)

- 2 (a) A disc attached to a rotating shaft is shown in **Fig. 6** along with the symbol for a normally open reed switch that is to be utilised to detect the rotation of the disc.

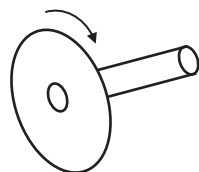

rotating disc



reed switch symbol

Source: CCEA

Fig. 6

- (i) Explain how the contacts of a reed switch which are normally open can be closed.

[2]

- (ii) Draw a labelled circuit that uses the reed switch shown in **Fig. 6** to provide a 5V output voltage when the reed switch is operated and 0V when the reed switch is not operated.

[2]

- (iii) Show with the aid of a labelled sketch how the disc shown in **Fig. 6** could be modified to enable it to operate a reed switch twice in one complete rotation.

[2]

Examiner Only	
Marks	Remark

- (ii) The output voltage from a phototransistor circuit is to be used as an input to a logic circuit. It has been suggested that connecting a Schmitt trigger between the phototransistor circuit and the logic circuit as shown in **Fig. 7** would improve the practical function of the system.

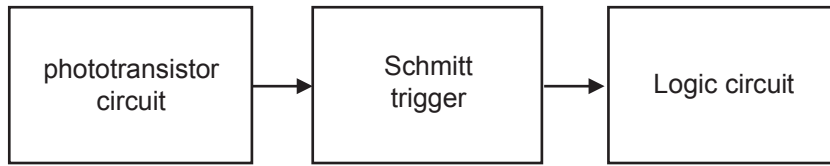

Source: CCEA

Fig. 7

Explain **one** main practical advantage of connecting a Schmitt trigger between the output of a phototransistor circuit and the input of a logic circuit as shown in **Fig. 7**.

[2]

- (iii) Show with the aid of a circuit diagram how the output voltage from a phototransistor circuit could be connected to a Schmitt trigger to provide an input to a logic circuit.

[2]

Examiner Only	
Marks	Remark

- (f) Components moving on a stepper motor-driven conveyor belt are shown in **Fig. 11**. After the components have been quality checked they are moved forward unless they have failed, in which case they are swept off the conveyor by a sweeper arm driven by a 12 volt DC motor. The conveyor stepper motor is a 24 volt type with a step angle of 1.5° .

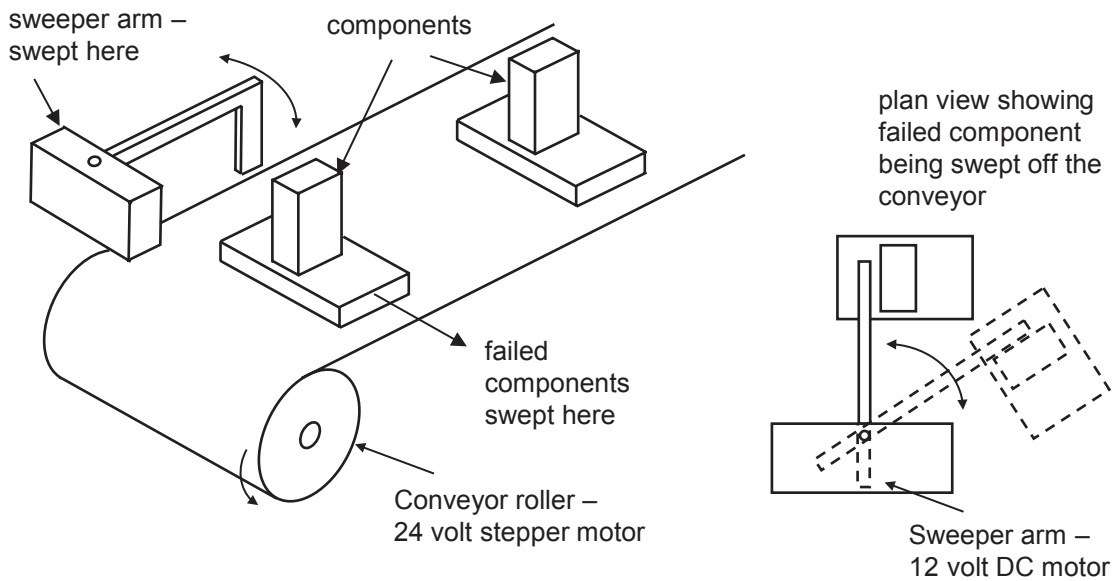

Source: CCEA

Fig. 11

On the blank pages following design a suitable PIC based circuit and associated flowchart that will achieve the following:

- The stepper motor should run continuously clockwise at a speed of 30 RPM until a momentary 5 volt logic signal is detected from the quality control logic circuit at which point the stepper motor should stop for a 5 second delay.
- During the 5 second delay the DC motor should run for 2.5 seconds in a clockwise direction to sweep the component off the conveyor.
- The DC motor should then reverse for 2.5 seconds where it should remain in position in preparation for the next component.
- The stepper motor should then resume clockwise rotation at 30RPM until another 5 volt signal is detected.

[10]

Examiner Only	
Marks	Remark

Answer page question 2(f)

Answer page question 2(f) (continued)

BLANK PAGE

(Questions continue overleaf)

Section B

Mechanical and Pneumatic Control Systems

Answer **both** questions in this section.

- 3 (a) (i) Outline **two** safety risks associated with the use of a pneumatic system and **one** procedure used to minimise each risk.

Risk

[1]

Procedure

[1]

Risk

[1]

Procedure

[1]

- (ii) Ball and socket joints are used on the selfie stick shown in **Fig. 12**. Using an annotated sketch in the space below outline the main features of a ball and socket joint and briefly explain why it would be selected in applications such as a selfie stick.

[3]

Examiner Only	
Marks	Remark

(b) The ferry shown in **Fig. 13** contains a prototype range of mechanisms used to control the output speed of the drive shaft.

(i) Calculate the velocity ratio from gear **A** to gear **N** in **Fig. 14**.



© Getty Images

Fig. 13

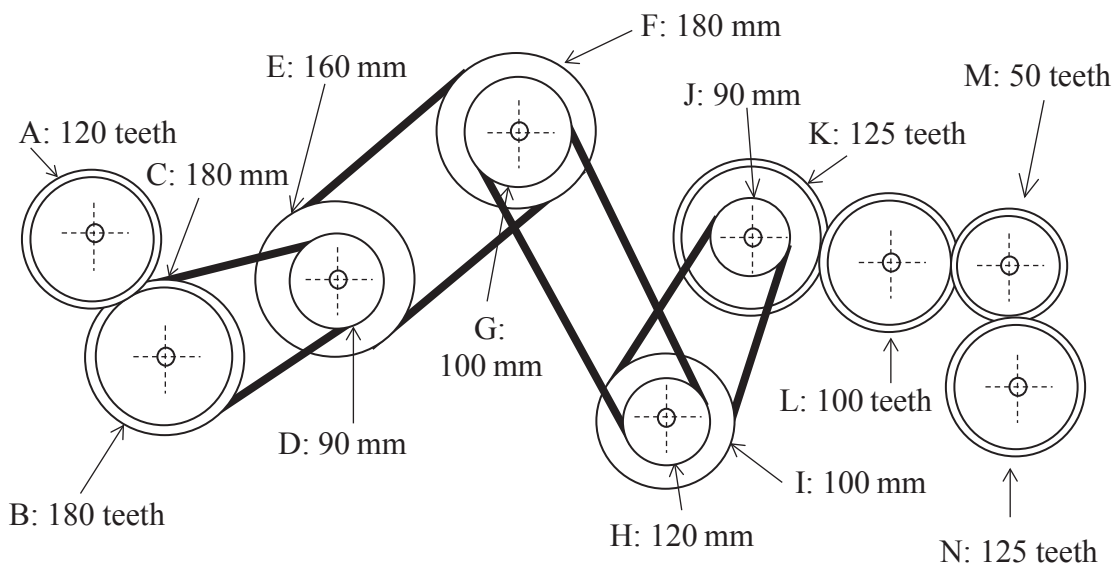

Source: CCEA

Fig. 14

Examiner Only	
Marks	Remark

Answer _____ [2]

- (ii) Calculate the efficiency of the system from pulley E to gear K if the mechanical advantage is 0.36.

Answer _____ [2]

Examiner Only	
Marks	Remark

- (d) (i) The drive system mechanism on the ferry is activated by a chain and sprocket.

Outline **one** advantage and **one** disadvantage of using a chain and sprocket for this system.

Advantage

_____ [1]

Disadvantage

_____ [1]

- (ii) Complete the circuit in **Fig. 15** to enable the one-way trip to ring the alarm bell on the ferry. The one-way trip will activate cylinder C to enable the clapper to strike the bell once and then return. [4]

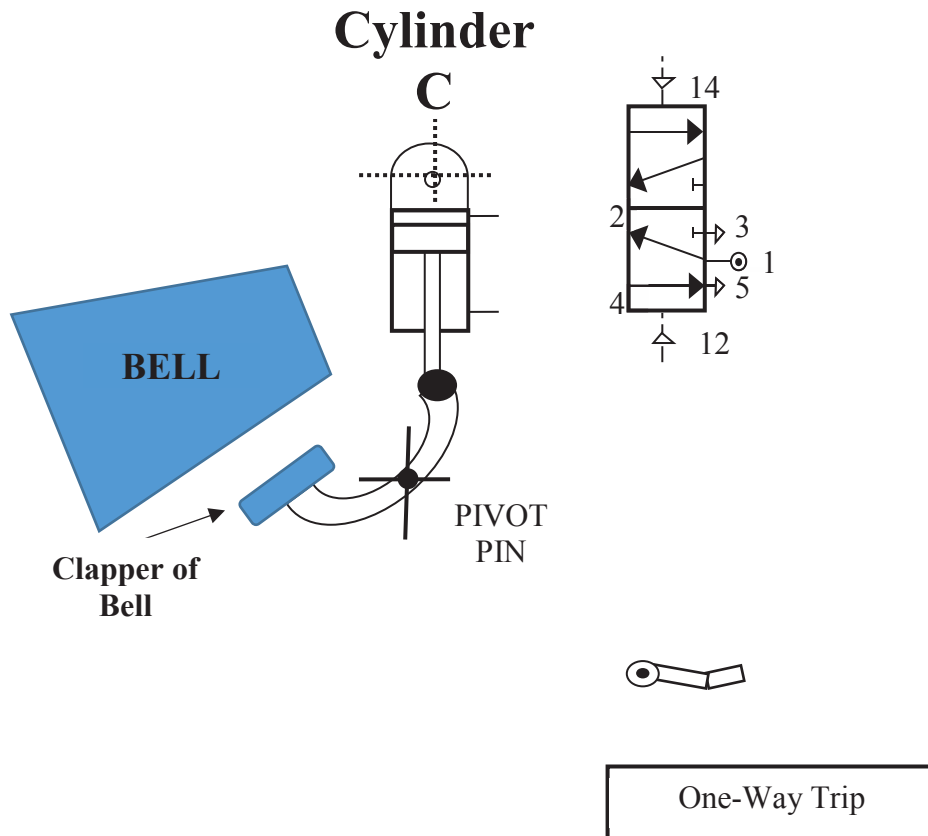

Fig. 15

Source: CCEA

Examiner Only	
Marks	Remark

(e) **Fig. 16** shows an image of the ferry used to transport vehicles over water. On the pro formas provided (answer number **3(e)(i) & (ii)**) design, draw and annotate an appropriate system which would achieve the following requirements:



© Getty Images

Fig. 16

- (i) Safely move the ferry life raft holder to the position shown. The outcome should be a suitable mechanism that will connect to the motor and will lift the holder from the lower position to the higher position as shown. Your design should incorporate a suitable mechanism. [4]

- (ii) Enable the vehicle barriers A and B to rise together and lower together using a mechanism. The chosen mechanism must operate the barriers together using the indicated motor. [6]

Examiner Only	
Marks	Remark

Examiner Only	
Marks	Remark

- 4 (a) (i) Select and briefly justify a suitable seal between an engine housing and a rotating shaft as shown in Fig. 17.

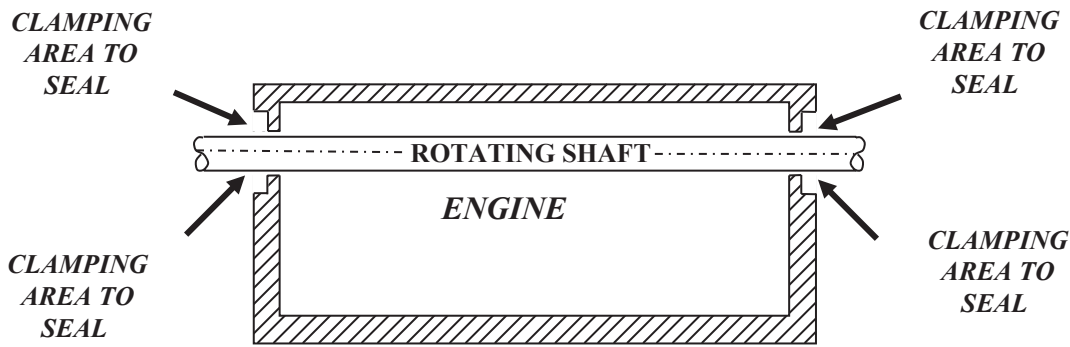

Source: CCEA

Fig. 17

Selection of a suitable seal: _____ [1]

Brief justification:

 _____ [1]

- (ii) A winch in a factory uses a band brake as a safety device. When activated the brake prevents the winch from rotating. With the use of an annotated sketch draw a band brake. Include in your sketch a method to activate this brake.

[3]

- (iii) The winch hook pulls a load with a mass of 2000 kg up a vertical height and gains 127660 J in potential energy before stopping. Calculate the vertical height the load is lifted. Assume $g = 9.82 \text{ m/s}^2$ and ignore friction.

Answer _____ m [3]

Examiner Only	
Marks	Remark

(b) Within a factory a range of pneumatic systems is used. Complete the following sequence on the A3 pro forma (answer number **4(b)**) using the minimum number of groups. Some of the piping has been completed on the pro forma to assist you. The sequence begins:

- By closing guard A AND B AND C the sequence will be activated sending Cylinder B positive.
- When Cylinder B is in the positive position it will send Cylinder C negative.
- Then Cylinder C goes positive which will send Cylinders D1 and D2 positive.
- Following a time delay Cylinders D1 and D2 will be sent negative. This will then send Cylinder A negative.
- Following detection by an air bleed Cylinder A then goes positive. This in turn will enable Cylinder B to go negative. [10]

(c) (i) Complete the circuit in **Fig. 18** to enable the double acting cylinder to accurately move positive and negative with the use of a 5/3 valve. The 5/3 valve must be activated by both valve A and valve B. Also, provide an explanation on how the 5/3 valve allows a high level of control. [3]

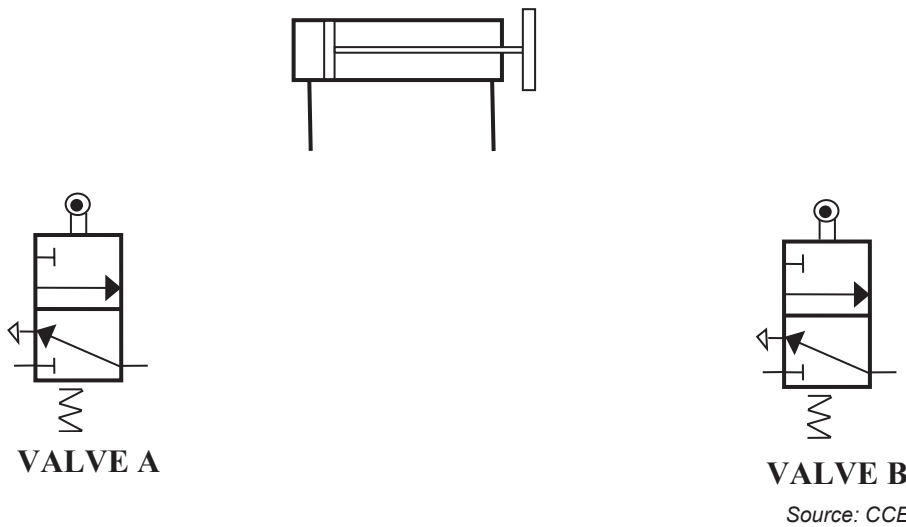

Explanation:

[2]

Examiner Only	
Marks	Remark

- (ii) The double acting cylinder A in **Fig. 19** operates with an air pressure of 0.5 N/mm^2 and has a cylinder radius of 30 mm . It is intended to replace double acting cylinder A with two smaller identical double acting cylinders B1 and B2 which operate with the same air pressure of 0.5 N/mm^2 . Calculate the radius of B1 and B2 in order to provide the same combined outstroke force as cylinder A.

Assume $\pi = 3.14$ and ignore friction.

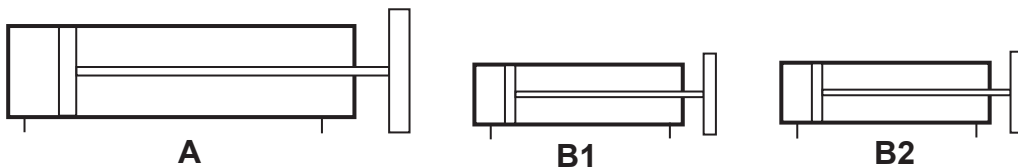

Fig. 19

Source: CCEA

Answer _____ mm [3]

- (iii) With reference to **Fig. 20** and the data below calculate the volume of air for the compressor if the double acting cylinder completes 10 return cycles.

Assume $\pi = 3.14$ and ignore friction.

$D = 20 \text{ mm}$

$S = 60 \text{ mm}$

$d = 10 \text{ mm}$

Gauge pressure = 4

Atmospheric pressure = 1.5

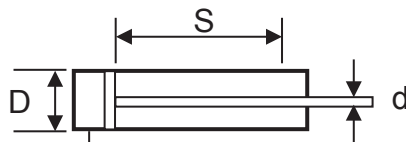

Source: CCEA

Fig. 20

Answer _____ mm^3 [4]

(d) On the pro forma provided (answer number 4(d)) design, draw and annotate an appropriate system which would achieve the following requirements:

As vehicles are loaded onto a transporter an air bleed sensor has been installed which will activate a counter to display the total number of vehicles onboard. The air bleed will also activate a double acting cylinder which will rotate the 'Caution Vehicles Onboard' sign by 90 degrees (to the horizontal position). A mechanical solution will be required to rotate the sign. Activation of microswitch A will enable the double acting cylinder to instroke to rotate the sign back to the vertical position. [10]

Examiner Only	
Marks	Remark

Section C

Product Design

Answer **both** questions in this section.

- 5 **Fig. 21** shows a photograph of a hoverboard which is an innovative product which provides a convenient and exciting form of transportation and fun for young people.



Source: © Getty Images

Fig. 21

- (a) Getting a product to the right place at the right time is an important consideration for any company.

Explain why it is so important for a company producing hoverboards to get their product to the right place at the right time.

[2]

Examiner Only

Marks

Remark

(e) The company designing and manufacturing the hoverboards gives careful consideration to the management of waste, the disposal of products and the use of environmentally friendly manufacturing processes.

(i) Briefly outline **two** different environmental reasons why it is so important for product designers and manufacturers to consider the management of waste.

1. _____

2. _____

_____ [2]

(ii) Briefly outline **two** different ways in which product designers and manufacturers can start to address environmental concerns through the disposal of their products.

1. _____

2. _____

_____ [2]

(iii) With reference to a manufacturing process of your choice explain how this process may be considered to be environmentally friendly.

_____ [2]

Examiner Only

Marks

Remark

(h) Feedback from consumer trials of the hoverboard shown in **Fig. 21** suggested that users being introduced to the product would like to have handlebars which could be adjusted to facilitate balance and help gain confidence. These adjustments would need to allow for different users with varied personal settings. The handlebar is to be attached to the aluminium alloy frame shown in **Fig. 22**.

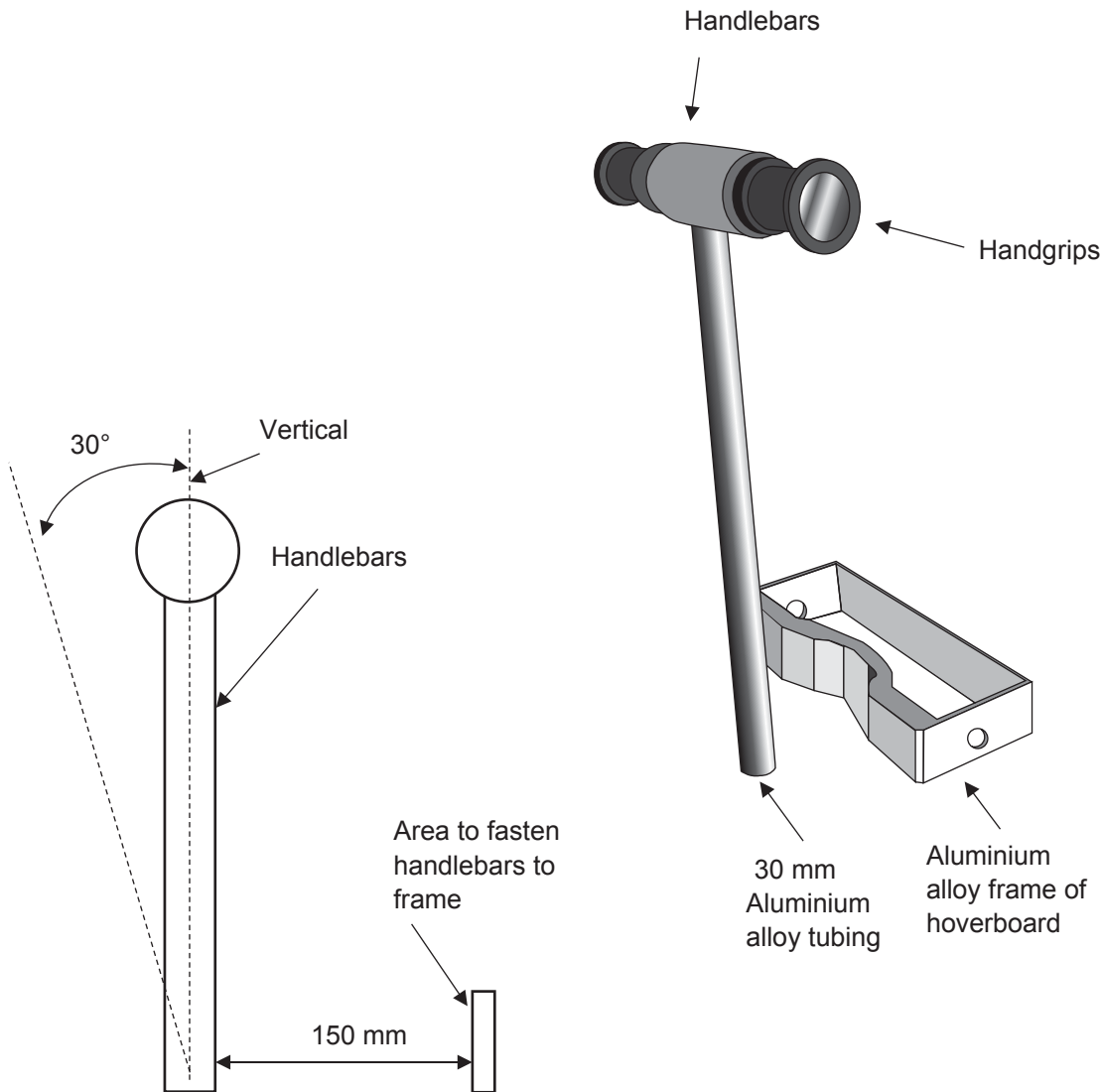

Source: © Principal Examiner

Fig. 22

With reference to **Fig. 22** and on the blank A3 pro forma (answer number **5(h)**) use detailed annotated sketches to produce **one** possible solution for the following:

An appropriate design which would allow the user without the use of hand tools, to quickly move and secure the handlebars at a convenient angle for the user, up to a maximum of 30° from the vertical. Your design must be securely connected to the frame of the hoverboard and must hold the handlebars at a distance of 150 mm from the frame. Show how your design has minimised the use of materials and processes and is suitable for large scale production. [10]

Examiner Only	
Marks	Remark

BLANK PAGE

(Questions continue overleaf)

- 6 Fig. 23 shows a photograph of a basketball hoop stand primarily aimed at helping children to exercise and develop hand-eye coordination.



© Getty Images

Fig. 23

- (a) Like many other products the basketball hoop stand has experienced the inception stage of the product life cycle.

Explain what is meant by the inception stage of the product life cycle.

[2]

Examiner Only	
Marks	Remark

(b) In order to improve the business opportunities of the company a marketing strategy suggested an increased focus on market development and product development.

Outline **two** characteristics associated with each of the following:

(i) Market development

1. _____

2. _____
_____ [2]

(ii) Product development

1. _____

2. _____
_____ [2]

Examiner Only	
Marks	Remark

(c) Introduction, growth, maturity and decline are stages in the life cycle of products such as the basketball hoop stand shown in **Fig. 23**.

(i) Compare the volume of sales expected during the growth stage in the life cycle of a product to the volume of sales expected during the maturity stage.

[2]

(ii) Compare the marketing costs expected during the introduction stage in the life cycle of a product to the marketing costs expected during the decline stage.

[2]

(d) Designers when selecting a material for the basketball hoop stand considered responsible sourcing and recycled content.

(i) Outline **two** characteristics associated with responsible sourcing when selecting a material for a product or component.

1. _____

2. _____

[2]

(ii) Outline **two** characteristics associated with recycling content when selecting a material for a product or component.

1. _____

2. _____

[2]

Examiner Only	
Marks	Remark

- (e) When planning to manufacture the product, the company considered a quick response manufacturing (QRM) approach.

Explain **two** benefits of QRM which could be used to persuade the company to adopt this approach.

1. _____

2. _____

_____ [4]

- (f) In trying to increase product sales the company considered the limitations that the use of sales promotion may offer.

Briefly outline **two** advantages and **two** disadvantages associated with the use of sales promotion as a way of increasing product sales.

Advantage 1.

_____ [1]

Advantage 2.

_____ [1]

Disadvantage 1.

_____ [1]

Disadvantage 2.

_____ [1]

Examiner Only

Marks

Remark

(g) Information and Communication Technology (ICT) plays an important role in the delivery of Quality Control (QC) and Quality Assurance (QA) systems.

(i) Describe **one** example of how ICT may be used in the delivery of a QC system.

 [2]

(ii) Describe **one** example of how ICT may be used in the delivery of a QA system.

 [2]

(h) Products can incorporate moral and/or economic factors in their design.

(i) Describe **one** example of a product which incorporates moral factors in its design.

 [2]

(ii) Using a different example describe a product which incorporates economic factors in its design.

 [2]

Examiner Only	
Marks	Remark

- (i) During consumer trials of the basketball stand shown in **Fig. 24** below, feedback suggested that users would like to house a smaller hoop, spanner and hand pump on the reverse side of the backboard. In addition, it was suggested that the ballast base needed to be redesigned to make it easier to move the basketball stand whilst providing support to the vertical pole.

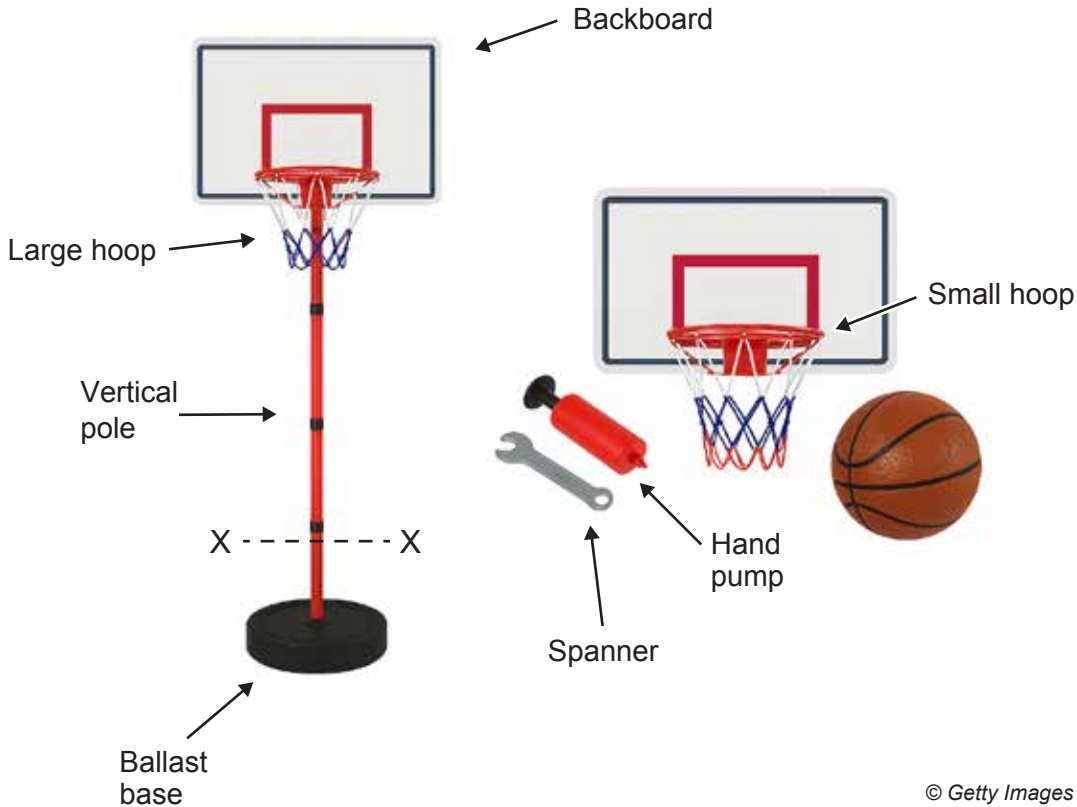

Fig. 24

With reference to **Fig. 24** and on the blank A3 pro forma (answer number **6(i)(i) & (ii)**) use detailed annotated sketches to produce **one** possible solution for the following:

- (i) An appropriate redesign of the ballast base to make it easier to move the basketball stand whilst providing additional support to the vertical pole at X–X. [5]
- (ii) An appropriate design for the reverse side of the backboard that would enable the small hoop, spanner and hand pump to be securely housed in an enclosure to protect them from the outdoor weather conditions. In addition, your design should facilitate the quick removal of these items for use and the quick replacement after use. [5]

Examiner Only	
Marks	Remark

THIS IS THE END OF THE QUESTION PAPER

Permission to reproduce all copyright material has been applied for.
In some cases, efforts to contact copyright holders may have been unsuccessful and CCEA
will be happy to rectify any omissions of acknowledgement in future if notified.